

MP35005W thru MP3510W

35.0 A Single-Phase Silicon Bridge Rectifier Rectifier Reverse Voltage 50 to 1000V



Features

- This series is UL listed under the Recognized Component Index
- Integrally molded heat sinks provide low thermal resistance for maximum heat dissipation
- Surge overload ratings to 400 amperes
- The plastic material used carries Underwriters Laboratory flammability recognition 94V-0
- Universal 4-way terminals, snap-on, wrap-around, solder or P.C. Board mounting
- High temperature soldering guaranteed 265°C/10 seconds at 5 lbs (2.3kg) tension

Mechanical Data

Case: Molded plastic with heat sink integrally mounted in the bridge encapsulation

Terminals: Plated copper leads .040" (1.02mm) diameter

Mounting Position: Bolt down on heat-sink with silicone thermal compound between bridges and mounting surface for maximum heat transfer efficiency

Mounting Position: Any

Weight: 0.706 ounce, 20 grams (approx)

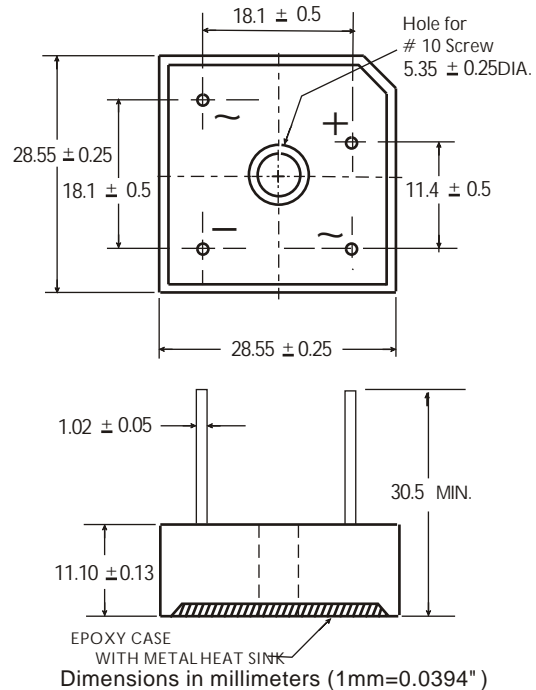

Maximum Ratings & Thermal Characteristics

Rating at 25°C ambient temperature unless otherwise specified, Resistive or Inductive load, 60 Hz.
For Capacitive load derate current by 20%.

Parameter	Symbol	MP35005W	MP3501W	MP3502W	MP3504W	MP3506W	MP3508W	MP3510W	unit
Maximum repetitive peak reverse voltage	VRRM	50	100	200	400	600	800	1000	V
Maximum RMS bridge input voltage	VRMS	35	70	140	280	420	560	700	V
Maximum DC blocking voltage	VDC	50	100	200	400	600	800	1000	V
Maximum average forward rectified output current at TA=55°C	IF(AV)	35							A
Peak forward surge current single sine-wave superimposed on rated load (JEDEC Method)	IFSM	400							A
Rating for fusing (t<8.3ms)	I ² t	664							A ² sec
Typical thermal resistance per element(1)	ReJA	2.1							°C/W
Operating junction and storage temperature range	TJ, TSTG	-55 to + 150							°C

Electrical Characteristics

Rating at 25°C ambient temperature unless otherwise specified. Resistive or Inductive load, 60Hz.
For Capacitive load derate by 20 %.

Parameter	Symbol	MP35005W	MP3501W	MP3502W	MP3504W	MP3506W	MP3508W	MP3510W	Unit
Maximum instantaneous forward voltage drop per leg at 17.5A	VF	1.0							V
Maximum DC reverse current at rated TA =25°C DC blocking voltage per element TA =125°C	IR	10 500							μA

Notes: (1)Thermal resistance from Junction to Ambient on P.C.board mounting.

Rating and Characteristic Curves ($T_A=25^{\circ}\text{C}$ Unless otherwise noted)
MP35005W thru MP3510W

Fig. 1 Derating Curve for Output Rectified Current

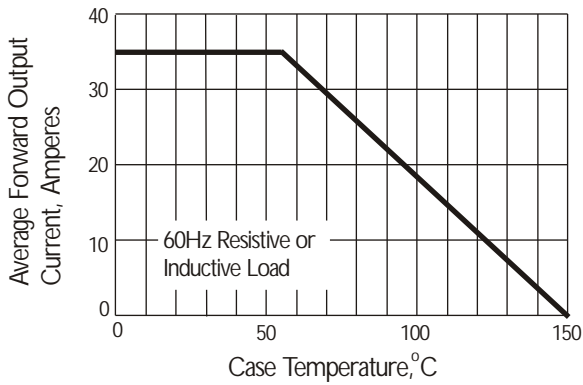

Fig. 2 Maximum Non-repetitive Peak Forward Surge Current

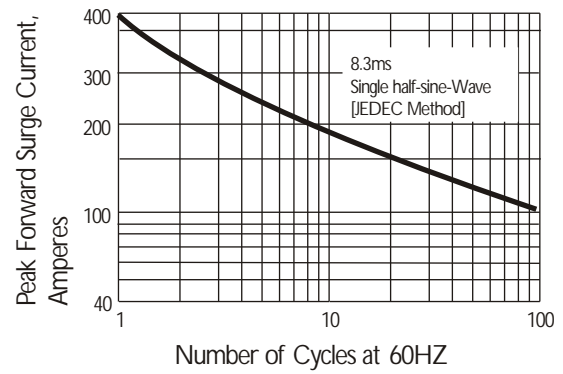

Fig. 3 Typical Instantaneous Forward Characteristics

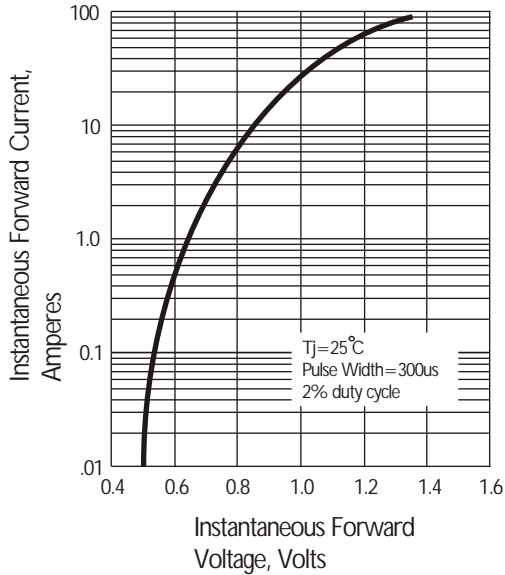

Fig. 4 Typical Reverse Characteristics at $T_J=25^{\circ}\text{C}$

